

PORKKA

KF, KFP Series Automatic Flake Ice Machines



For bars, cafes, restaurants and hotels

KF KFP Series Automatic Flake Ice Machines



Porkka Automatic Flake Ice Machines produce a dry free-flowing flake ice that is ideal for salad bar displays, cooling of white wines or champagne and cocktails where crushed ice is required. They can be used in hotels, restaurants, cafes and nightclubs when a more sophisticated display is required to enhance customer appeal.



KF KFP Series Automatic Flake Ice Machines

Porkka ice flakers produce ice flakes that are dry and compact, this allows the ice to remain free flowing for easy use even after long storage periods.

The ice is ideal for use in restaurants, hotels and for salad bars, food displays and cocktails.

Built using the most up to date technology Porkka ice flakers are designed to produce ice year after year, quietly and efficiently.



KF85

AVAILABLE WITH
R290
REFRIGERANT

Features

- Bodywork made from stainless steel grade AISI 304
- One piece insulated and moulded food safe ABS plastic storage bin
- Ice produced using a vertical evaporator with endless screw
- Belt driven gearbox
- Bin thermostat (models with integrated storage bins)
- Electronic eye sensor (models without integrated bins)

Optional Features

- Front ventilation for model KF 75
- Water cooled condenser
- Voltage 230V/60Hz or 115V/60Hz

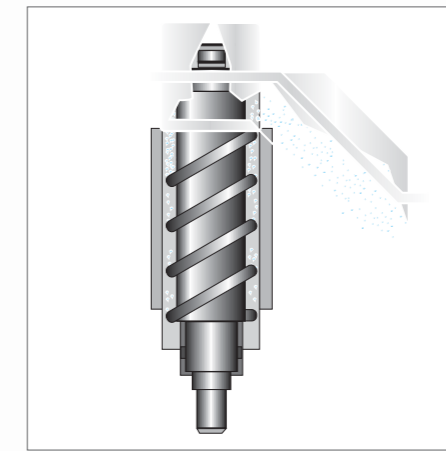

KF machines produce flake ice using the Auger method. Tried and tested over the years these machines produce quality flake ice at competitive prices.

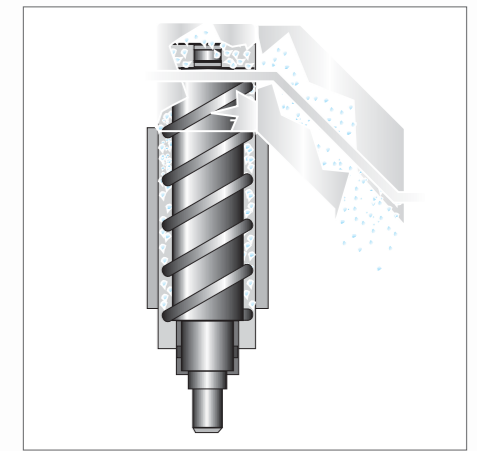

KF-P machines produce pressed flake ice at -0.5°C. This is a drier ice which lasts longer on display and is preferred in some processes.



KF45



**KF85 (E)
KFP85 (E)**



**KF145 (E)
KFP145 (E)**

Specifications

	KF45 (E)		KF85 (E)/KFP85 (E)		KF145 (E)/KFP145 (E)	
	A	W	A	W	A	W
Air cooled/Water cooled						
Production Kg/24h - KF	40	42	80	83	135	141
Production Kg/24h - KFP			75	78	120	125
Width (mm)	345		485		680	
Depth (mm)	520		586		588	
Height (mm) (feet)	610 + (25)		720 + (140)		890 + (140)	
Bin Storage (Kg)	10		25		42	
Connection Power (kW)	0.41		0.52		0.59	
Voltage	230V/50Hz		230V/50Hz		230V/50Hz	
Gross Weight (kg)	41		62		76	

(E) = available with R290 refrigerant



KF185 (E)

**KF200 (E)
KFP200 (E)**

**KF300 (E)
KFP300 (E)**

Specifications

Air cooled/Water cooled	KF185 (E)		KF200 (E)/KFP200 (E)		KF300 (E)/KFP300 (E)	
	A	W	A	W	A	W
Production Kg/24h - KF	175	183	195	205	300	305
Production Kg/24h - KFP			175	180	270	275
Width (mm)	953		560		560	
Depth (mm)	590		511		511	
Height (mm) (feet)	781 + (140)		560		560	
Bin Storage (Kg)	60		-		-	
Connection Power (kW)	0.65		0.8		1.15	
Voltage	230V/50Hz		230V/50Hz		230V/50Hz	
Gross Weight (kg)	94		78		78	

(E) = available with R290 refrigerant



KF600

KF1200

KF2500

Specifications

Air cooled/Water cooled	KF600		KF1200		KF2500	
	A	W	A	W	A	W
Production Kg/24h	600	615	1150	1165	2300	2330
Width (mm)	750		900		1146	
Depth (mm)	561		626		692	
Height (mm)	692		872		1120	
Bin Storage (Kg)	-		-		-	
Connection Power (kW)	1.95		3.6		2x3.6	
Voltage	230V/50Hz		230V/50Hz		230V/50Hz	
Gross Weight (kg)	122		180		320	



KFP450

KFP950

KFP1750

Specifications

Air cooled/Water cooled	KFP450		KFP850		KFP1750	
	A	W	A	W	A	W
Production Kg/24h	485	490	970	980	1700	1720
Width (mm)	750		900		1146	
Depth (mm)	561		626		692	
Height (mm)	692		872		1120	
Bin Storage (Kg)	-		-		-	
Connection Power (kW)	1.95		3.6		2x3.6	
Voltage	230V/50Hz		230V/50Hz		230V/50Hz	
Gross Weight (kg)	122		180		320	



B/BF150

B/BF250

Specifications

Width (mm)	B150	BF150	B250	BF250
	890	Essential for operation	1200	Essential for operation
Depth (mm)	845	-	845	-
Height (mm) (feet)	764 + (140)	-	764 + (140)	-
Bin Storage (Kg)	150	-	250	-
Gross Weight (kg)	63	7	84	8

Porkka in Finland is an internationally recognised designer and manufacturer of Refrigeration and Food Storage/Display Equipment

Porkka in Finland is an internationally recognised designer and manufacturer of Refrigeration and Food Storage/Display Equipment. The range incorporates Chilled, Frozen and Heated options. Major clients include commercial kitchens, restaurants, fast food outlets, hotels, industrial canteens, hospitals, laboratories and retailers throughout the World.

Our main markets outside of Finland include Scandinavia, United Kingdom, Germany, Switzerland, Holland, Belgium, Russia and the Baltic regions. 80% of the companies' turnover is derived from foreign transactions and exports. On going and adaptive development by numerous foreign subsidiaries and representatives ensures our continued growth.

Porkka's success is based on decades of experience, customer focused design and continuous product development.

Porkka is part of the Huurre Group. Porkka and Huurre brands are well known for their quality and reliability throughout the world.



Porkka designs and manufactures to a quality standard ISO 9001 which is controlled and certified by Lloyd's Register Quality Assurance. We also hold the environmental certificate ISO 14001 which also has been issued by LRQA, where environment impact in production is kept to a minimum.

CE marked products. The manufacturer through continuous research and development reserves the right to change technical specification and design without notice.

Porkka reserves the right to make any changes without prior notice.

PORKKA

Porkka in Finland
Mukkulankatu 19
FI-15210 Lahti, Finland
Tel. +358 20 5555 12
Fax +358 20 5555 497
e-mail: contact@porkka.com
www.porkka.com

Porkka in Sweden
Industrigatan 21
S-61933 Trosa, Sverige
Tel. +46 156 348 40
Fax +46 156 167 50
e-post: porkka@porkka.se
www.porkka.se

Porkka in Norway
Lensmannslia 30
N-1386 Asker, Norge
Tel. +47 66 98 77 77
Fax +47 66 98 77 88
e-post: salg@porkka.no
www.porkka.no

Porkka in UK
29B Greenhill Crescent
Watford Business Park, Watford
Hertfordshire, WD18 8YB, UK
Tel. +44 1923 23 36 75
Fax +44 1923 80 57 17
e-mail: sales@porkka.co.uk
www.porkka.co.uk