

Haier



Laboratory Refrigerator with explosion-proof interior Operation Manual

Model:
HLR-118FL
HLR-118SF
HLR-310FL
HLR-310SF

Certificate of Quality

checker:



Manufacturer: Haier Medical and Laboratory Products Co., Ltd.
Address: Haier Industrial Park, Economic Technology Development
Zone, Qingdao 266510, P.R. China
Web: www.haiermedical.com
Modified date: 11/2017
Version: 1st, 2017
Dedicated code: 0270501316
V13026

- Please read this instruction carefully before using.
- Our company reserves the right to interpret the User's Manual.
- The appearance of the product is subject to material objects.
- This product is subject to technology or software upgrade without further notice.



Packing List

| Name | HLR-118FL | HLR-118SF | HLR-310FL | HLR-310SF |
|-----------------------|-----------|-----------|-----------|-----------|
| Specification | | 1 | | 1 |
| Basket | | 1 | | / |
| Key | | 2 | | 2 |
| Plastic bag | | 1 | | 1 |
| Glass shelf | | 2 | | 4 |
| Water collection tray | | 1 | | 1 |

Specification

| Name | Laboratory Refrigerator with explosion-proof interior | | | |
|---|---|-----------|--|-----------|
| Model | HLR-118FL | HLR-118SF | HLR-310FL | HLR-310SF |
| Outside dimension (W×H×D)(mm) | 597×635×835 | | 605×598×1840 | |
| Internal dimensions(W×H×D)(mm) | 515×415×630 | | 560×500×1290 | |
| Effective volume | 118L | | 310L | |
| Door body | Foaming door | | Foaming door | |
| Insulating material | Hard polyurethane foam (fluorine-free) | | Hard polyurethane foam (fluorine-free) | |
| Compressor | Fully closed famous brand compressor | | Fully closed famous brand compressor | |
| Shelf | Glass shelves | | Glass shelves | |
| The loading of each shelf | ≤20kg | | ≤24kg | |
| Cooling mode | Forced-air cooling circulation | | Forced-air cooling circulation | |
| Outer/ Inner table | Spray coated steel plate /Permanent anti-static sheet/ PS plate | | | |
| Condenser/Evaporative | Wire and tube type / plate type | | Wire and tube type / plate type | |
| Temperature control | Microprocessor | | Microprocessor | |
| Refrigerant | R134a | | R600a | |
| Net weight | 44 kg | | 72kg | |
| Adjustable set temperature | 3°C -16°C | | 3°C -16°C | |
| Rated power supply | 220-240V~/50Hz | | 220-240V~/50Hz | |
| Type of protection against electric shock | I | | I | |
| Alarm stype | Hi-low temperature alarm, sensor fault alarm, door ajar alarm | | | |
| Production date /expected service life | See barcode on the cabinet/10 years | | | |
| Type of protection of explosion-proof inerior | ic,nA | | | |
| ATEX classification | Group II Category 3 G | | | |
| Ex Marking | Ex ic nA IIC T6 Gc | | | |
| Temperature class | T6 | | | |
| EU Examination Certificate Number | CML 17ATEX4222X | | | |
| Software release version | V4 | | | |

Haier quality,
it merits your trust from beginning to end.

Temperature Control

The product application scope: Temperature setting range 3°C ~ 16°C . Computer control and temperature numeric display with temperature display precision of 1°C .

Safety System

- Multiple fault alarms(Hi-low temperature alarm, sensor fault alarm, door ajar alarm)
- Two modes for alarm(sound buzzer and alarm lamp flickering)
- All independent assemblies have safe grounding

Refrigeration System

- Deeply optimized refrigeration system, famous brand of compressor and major components, better refrigeration performance

User-Friendly Design

- Humanized design of computer control mode, intelligent without anxiety, adjustment free
- High performance insulation layer with better thermal insulation effect

The refrigerator you obtained is probably not exactly the same as illustrated in the User's Manual due to continuous improvement of product, we regret for this. Content of this instruction is subject to alternation without prior notice.

Product Feature 1

Content 2

Safety Precautions 3

Precautions for Use..... 6

Product Installation 7

Component Names•Control Panel 11

Application method 13

Cleaning and Maintenance 15

FAQ 16

Fefrigeration Schematic&Circuit Diagram 17

Specification 20

Circuit Diagram

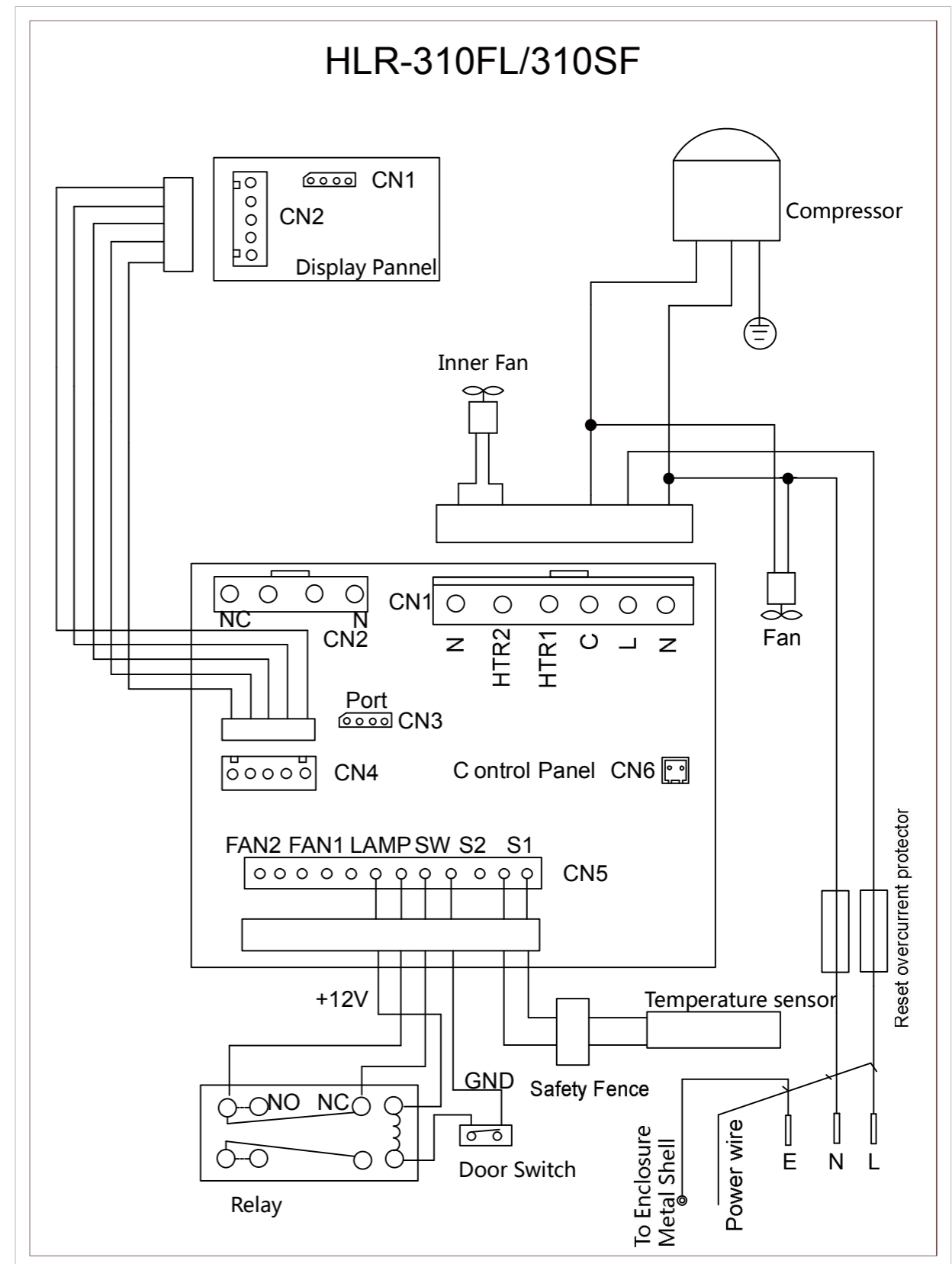

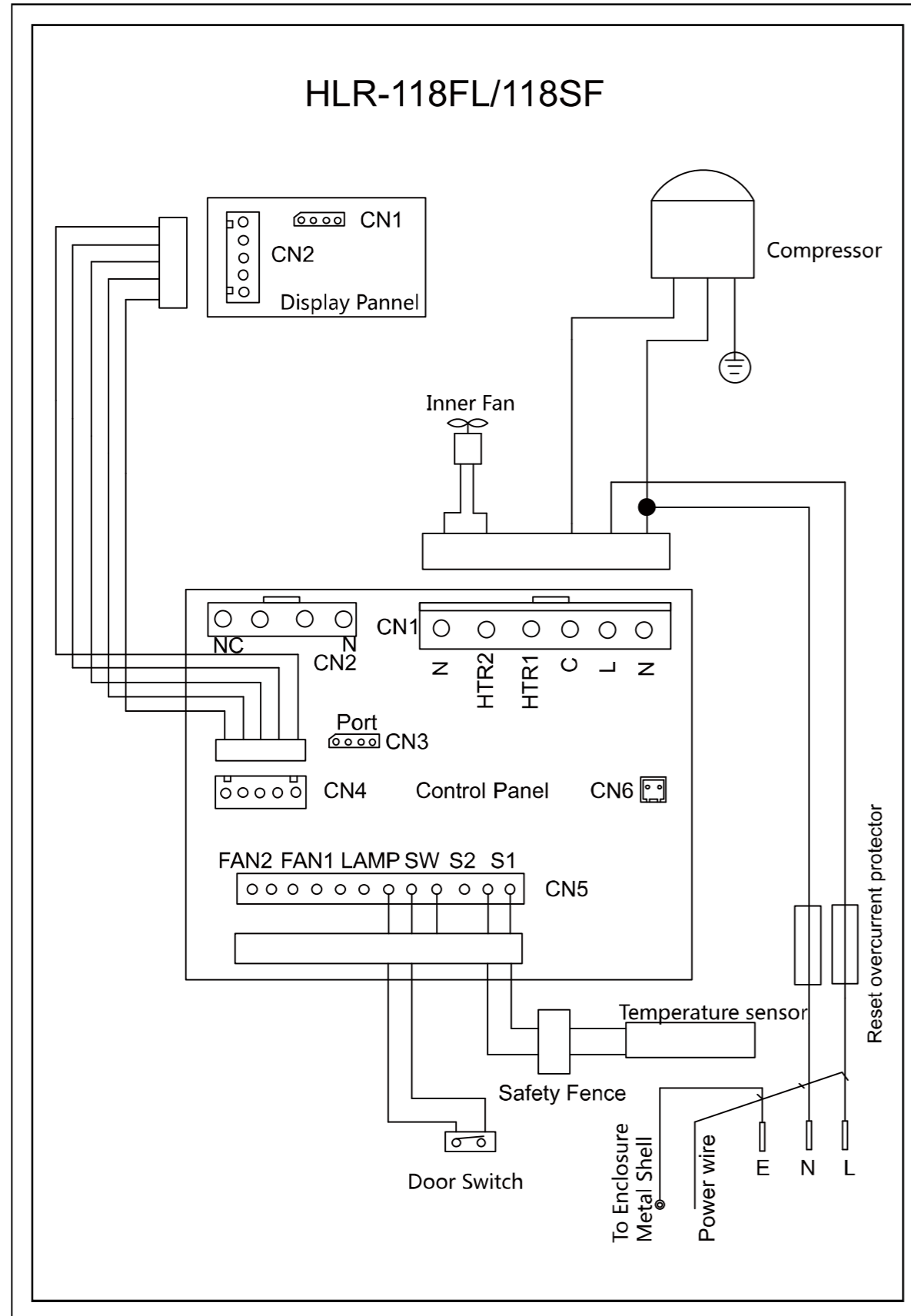

Circuit Diagram













Dear users:

Thanks for your choice of Haier laboratory refrigerator, please make sure you have carefully read and observed the contents with following signs in the manual, for better understanding of this manual and better use of this product, so as to prevent personal injuries and refrigerator damage.

 Actions or operations which are prohibited

 Actions or operations which must be followed

 Caution

-  Close down the gas leaking valve and open the door and windows for ventilation in case of leakage of inflammable gas like coal gas etc., do not insert or pull out the power plug of the refrigerator, otherwise it may trigger an explosion and fire.
-  Only the professional technicians or after-sale service men can install this refrigerator. Otherwise it may result in an electric shock or fire.
-  Make sure to place the refrigerator firmly on a solid and flat ground. If the ground is not stable or it is not properly placed, it will cause overturn of the refrigerator or personnel injury.
-  Please use the dedicated power supply indicated on the nameplate of the refrigerator, or otherwise, it may cause a fire or electric shock.
-  If it is required to lengthen the power cord, the section area of the lengthen cord must not be less than 2mm² and the length shall not be longer than 3m. Otherwise, it may cause a fire or electric shock.
-  The power cord of this refrigerator is provided with a three-wire (earthing) plug, complying with the standard 10A three-wire (earthing) socket. Never cut or remove the earthing pin of the power cord in any case. Make sure that the power plug and socket is inserted tightly and reliably, otherwise it may result in a fire.
-  Please use an earthed power supply socket for fear of electric shock.
-  If the power socket is not earthed, be sure to have the earth wire installed by a professional technician.
-  Do not use the refrigerator in the open air. When the refrigerator gets wet in the rainwater, it may cause leakage of electricity or electric shock.
-  Do not place the refrigerator in a damp site or a place where it may easily suffer from spraying water. Otherwise, it may cause leakage of electricity or electric shock due to degeneration of its insulation.
-  Do not pour water onto the refrigerator in a direct inclined way, otherwise it may cause an electric shock or a short circuit.

- ⊘ Do not place any vessel containing water or any heavy object on the refrigerator. If the object drops off, it may cause personal injury and the flowing water will degenerate the insulation and further cause leakage of electricity or electric shock.
- ⊘ Do not make the refrigerator earthed via a gas-pipe, power supply conduit, telephone line or lightning rod. The above earthing will cause an electric shock or other dangers.
- ! Do not contact any electric parts or any switches such as power plug and so forth with a wet hand, or otherwise it may cause an electric shock.
- ! When pulling out a plug from the power socket, hold the power plug firmly but do not pull the wire of the power plug. Pulling the wire with hand may cause an electric shock or lead to a fire due to short circuit.
- ⊘ If the refrigerator runs out of order, please pull out the power plug. Continuous running in an abnormal condition may cause an electric shock or fire.
- ! User must not dismantle, repair or refit the refrigerator by itself. Otherwise, it may cause a fire or personal injury due to improper operation.
- ! Before conducting any repair or maintenance of the refrigerator, be sure to disconnect the power of the refrigerator for fear of electric shock or personal injury.
- ! Make sure not to suck in medicine or suspended particles inside and surrounding the refrigerator in time of repair and maintenance, otherwise, it may bring hurt to your health.
- ! When storing toxic, hazardous or radioactive articles, please use the refrigerator in a safety zone.
- ! Improper use may bring hurt to human health or environment.
- ! If the refrigerator is left unused for a long time in an unattended area, make sure that children will not approach the refrigerator and the refrigerator door will not be closed completely.
- ! Disposal of discarded refrigerator shall be conducted by the relevant personnel. The appliance contains reusable materials and should be disposed of properly - not simply with unsorted household refuse. Appliances which are no longer needed must be disposed of in a professional and appropriate way, in accordance with the current local regulations and laws.
- ⊘ When disposing of the appliance, ensure that the refrigerant circuit is not damaged to prevent uncontrolled escape of the refrigerant it contains (data on type plate) and oil.
- ⊘ Do not store corrosive articles such as acid, alkali etc. in the refrigerator. Otherwise, it may spoil the internal units or electric parts of the refrigerator.
- ⊘ Do not place the packing plastic bags at the locations where children can easily take as plastic bags may cause occurrence of suffocation accident.
- ⊘ Do not climb up to the refrigerator or place articles on the refrigerator, otherwise it may cause personal injury or damage of refrigerator due to overturn of the refrigerator.
- ⊘ Do not insert any metal objects like iron nails, iron-wire into any orifice and gap or any air vent used for internal air circulation of the refrigerator, otherwise, it may cause an electric shock or injury due to contact of the above objects with the moving parts.

Refrigeration Schematic

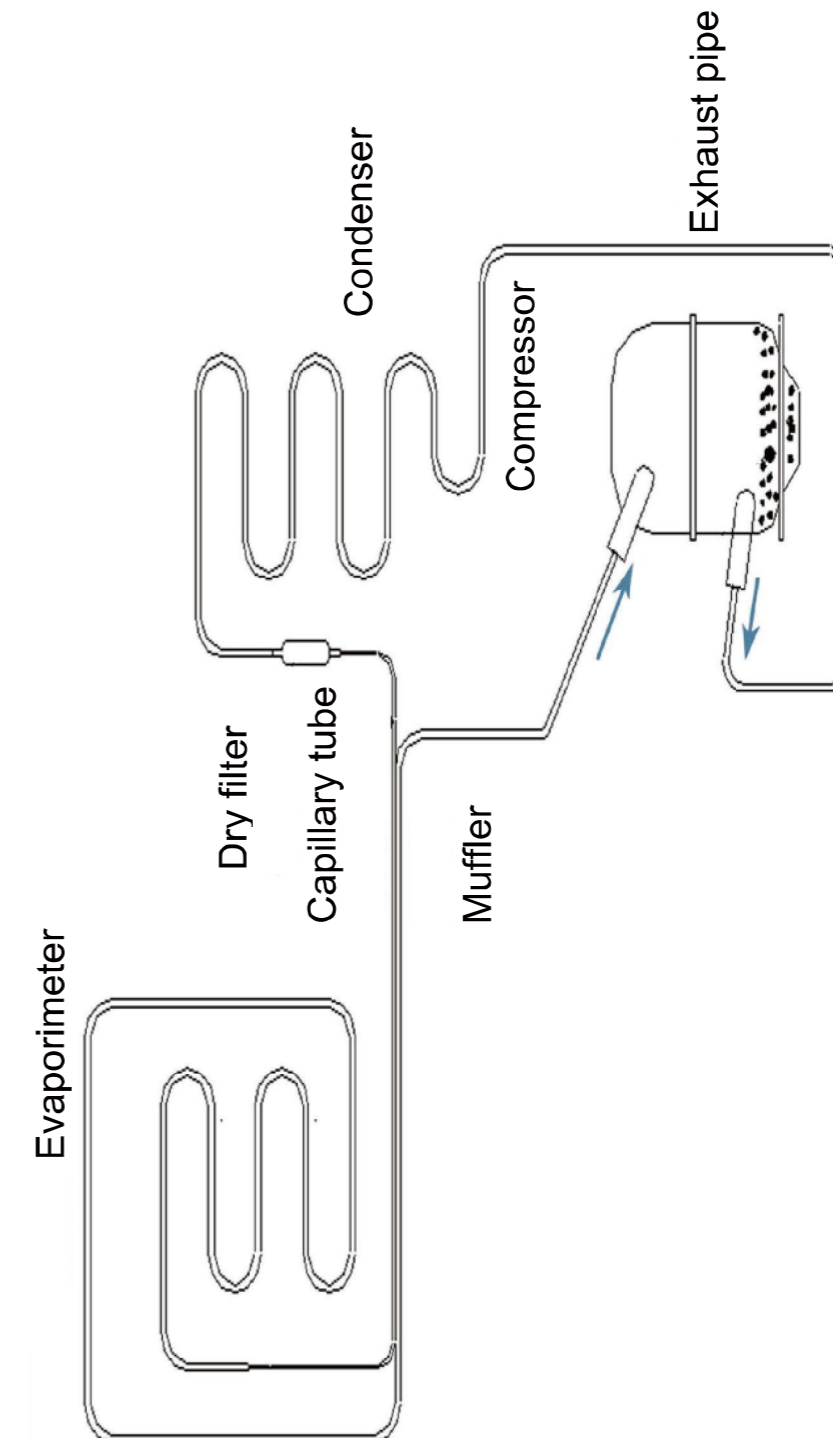



If you have any questions about the operation of the refrigerator, please refer to the table frequent asked questions as follows. Call Haier technical support if you still have questions. Do not attempt to maintain or dismantle the unit by yourselves.

| Fault | Troubleshooting |
|--|--|
| The refrigerator does not work | Inspect the power supply to make sure it meets therequirement |
| | Inspect the connection between the power plug and the socket |
| | Check the power cord for any obvious damage |
| | Whether the voltage is too low |
| Refrigeration effects are not apparent, temperature exceeds the standard | The unit is loaded with too much warm sample and product |
| | There is a lack of space between stored samples |
| | There might be a direct sunlight or other heat radiation energy on the refrigerator |
| | The door is opened too frequently |
| | Ambient temperature is too high |
| | Air duct is blocked |
| Unit seems to emit too much noise. | Check the installation of the unit to make sure the unit does sit on a solid floor without vibration |
| | Part of the refrigerator leans against a wall |
| | As a reference, the published sound data is obtained at specific laboratory condition. It is normal that the actual sound level in the field differs due to subtle installation and operation conditions |
| | Warm products have been placed into the unit recently and the refrigerator has not stabilized yet. The alarm condition will be automatically corrected once the temperature reaches the set value |
| Alarm light flashes and alarm buzzer sounds | The door is not closed properly |
| | The unit lost power recently and it is in the process of cooling down |
| | Ambient temperature might exceed the designed range |
| | |

- ! If the supply cord is damaged, it must be replaced by the manufacturer, its service agent or similarly qualified persons in order to avoid a hazard.
- ⊘ Do not store explosive substances such as aerosol cans with a flammable propellant in this appliance.
- ⊘ Keep clear of obstruction all ventilation openings in the appliance enclosure or in the structure for building-in.
- ⊘ Do not use mechanical devices or other means to accelerate the defrosting process, other than those recommended by the manufacturer.
- ⊘ Do not damage the refrigerant circuit.
- ⊘ Do not use electrical appliances inside the food storage compartments of the appliance, unless they are of the type recommended by the manufacturer.
- ⊘ In order to reduce flammability hazards the installation of this appliance must only be carried out by a suitably qualified person.
- ! For the product with non-conductive inner chamber(white), see the warning lable of product.
- ! Put explosive/flammable material in sealed container before storing into laboratory refrigerator.



- ! When restarting the refrigerator after a power failure or power-off, it is required to check the setting of the refrigerator. Change of setting may spoil the articles stored.
- ! Once the power of the refrigerator is cut off, wait for over 5 minutes before it is reconnected so as not to damage the compressor or the system.
- ! Put on your gloves at time of maintenance so as not to bump the sharp edges or corners, resulting in personal injury.
- ! Close the door of the refrigerator with your hand holding the handle so that your fingers will not be pinched by the door.
- ! The inclination angle shall be no greater than 45 ° when handling the refrigerator.
- ⊘ When handling the refrigerator, be careful not to trip over it, preventing damage to the refrigerator or personal injury.
- ⊘ Do not pull or carry the equipment by the door handle, preventing damage to the refrigerator or personal injury.
- ! There shall be no obstacles around the refrigerator, and keep it well-ventilated and clear.
- ⊘ Do not spoil the refrigerating circuit.
- ⊘ Do not use any electric appliance in the store-room of the refrigerator except for the types that the manufacturer recommended for use.

- Product structure and composition: The product adopts a refrigeration system attached to the thermal insulation box which is microcomputer controlled with air cooling design, and a rack type design that can be adjusted at discretion.

- Before putting the articles into the refrigerator, make sure firstly that the design temperature is reached inside the refrigerator, then put in the articles in batches. The articles put in every time shall not exceed 1/3 of the internal capacity so as to prevent temperature increase.

- The indicated temperature value of the refrigerator is the value indicated inside the refrigerator at the temperature sensing probe. Occasionally the indicated temperature has a certain difference with the actual temperature in the central part of the refrigerator, but it will gradually approach to the true temperature.

- Use the diluted mild detergent to clean the refrigerator. Do not use brushes, acid, gasoline, soap powder, polishing powder or hot water to clean the refrigerator as the above materials may damage the painting surface as well as the plastic and rubber parts and components. Take particular care not to use volatile solvent such as gasoline to wipe plastic and rubber parts and components.

- Cut off the power of the refrigerator when it is not in service for a long time.

- Every time when putting in and taking out the articles, please try to reduce the door opening time so as not to cause larger fluctuations of the temperature and humidity inside the refrigerator.

- After opening the door, the temperature inside the refrigerator will rise steeply in a short time, this is normal and the temperature will restore within one hour after the door is closed.

- The refrigerator is equipped with security door lock. Please keep the key properly. Once the key is lost, the door body of the refrigerator will not be opened

- Conformity with standards:

This explosion proof inner chamber meets the requirements of EN 60079-0, EN 60079-11 and EN 60079-15. It also complies with the EU Directives for "Equipment and protective systems intended for use in potentially explosive atmospheres"(2014/34/EU). It has been designed, manufactured and tested in accordance to the state of the art and according to ISO 9001. The inner part of the refrigerator suitable for use in explosive atmospheres, Zone2 according to IEC60079-10-1.

- Product model :

H L R - 118/310 FL/SF

Haier Laboratory Refrigerator Volume FL: Explosion proof type with electrostatic protection
SF: Explosion proof type without electrostatic protection

- Serial No. Instruction :

For example : Serial No.: BE06920BA00QEH8E0023

manufacture month, 8 represents August.

manufacture year H represents 2017

Component Cleaning



- In order to prevent an electric shock or personal injury, be sure to cut off the power of the refrigerator before conducting any repair to the refrigerator.

- Make sure not to suck medicine or suspended particles around the storage box when maintaining the refrigerator, otherwise, it will hurt your health.

Inner cleaning

The inner of the refrigerator are made of two types of plastic materials. The first is the permanent antistatic plastic material, which can be used to clean the plastic any time. The other one is the ordinary plastic material, which requires a regular cleaning of the plastic.

EXPLOSION-PROOF INTERIOR

Interior Temperature Range : +3 ~ +16 °C

Internal II3/- G Ex ic nA IIC T6 Gc

Certification No.: CML 17ATEX4222X

Serial No.: In the Barcode

Haier Medical and Laboratory Products Co., Ltd.



Anti-static operating instruction

1. clean plastic parts with a damp cloth only.
2. Do not use a dry cloth to clean plastic parts.
3. Danger of sparks due to electrostatic discharge.
4. Warning - potential electrostatic charging hazard - see instructions.



WARNING

Fan cleaning

Danger of sparks produced by friction due to dust on the fan blades. Clean the ventilation slots on the re-circulated air fan every month using a vacuum cleaner.

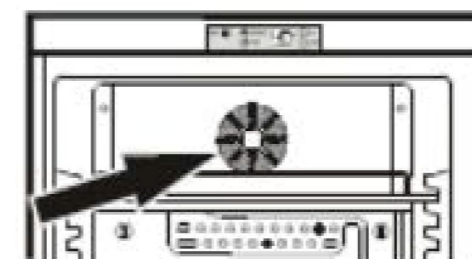

Stopping refrigerator

- Cut off the refrigerator power if the refrigerator is not in service for a long time;
- Open the refrigerator's door and take out the inner plate glass shelf;
- Make thorough cleaning of the refrigerator
- Clean the plate glass shelves.

Wait till the Refrigerator and the plate glass shelves are dried in the air, and replace the plate glass shelves in the refrigerator.

- Close the door of the refrigerator and cover it with a plastic bag for sealing up.

automatically exit and redisplay the box temperature value (no flickering) if no operation is made within 10s. After running for a period of time, the refrigerator box temperature will reach the set temperature.

- Fault display

This indicator has only one sensor fault display, in occurrence of a fault found with the sensor, the window displays EE and gives alarm, the refrigerator can still refrigerate in failure safe mode in a short time, but it is required to divert the articles stored to the other sound refrigerators as soon as possible and promptly contact the after-sale service department so as not to cause loss for you.

- Hi-low temperature alarm

In running process of the refrigerator, it will alarm if the temperature inside the box exceeds the hi-low temperature alarm limit, and the alarm indicator will flicker and buzzer beeps at the same time, the beeps can be cancelled by pressing the "Alarm" key, but the Alarm indicator will continue flickering until the temperature restores to the alarm limit.

- Query of alarm temperature

Press "Alarm" key and "+" key simultaneously to query the high temperature alarm limit, release and return to the box temperature display.

Press "Alarm" key and "-" key simultaneously to query the low temperature alarm limit, release and return to the box temperature display.

- Query of the recent max. & min. actual temperature values inside the box

Press "Set" key and "+" key simultaneously to query recent max. actual temperature value, release and return to display the temperature inside the box.

Press "Set" key and "-" key simultaneously to query recent min. actual temperature value, release and return to display the temperature inside the box.

- Adjustment of alarm limit

Set up the high temperature alarm limit (HA) and the low temperature alarm limit (LA) with the method below:

Keep pressing the "Alarm" key for over 10s, the code HA appears in the display window, press the Set key once (quick), the Original setting value of HA is displayed and flickering, adjust the setting value by pressing the up key "+" or down key "-", the setting value changes for 1°C for every press with the adjusting range of no higher than the temperature setting value of +6°C. Press the "Alarm" key to exit and return to HA display of the last layer (one layer return for each pressing of the Alarm key, till it returns to the temperature display of the box). Choose another parameter LA by pressing up key "+" or down key "-". The method for setting LA is same as above, its adjusting range is not lower than the box temperature setting value of -6°C.

Installation environment

- Environmental temperature : 16°C to 32°C , the optimal temperature is 18°C to 25°C , the air conditioning system shall be used when necessary.
- Ambient humidity: below 85% Rh.
- Avoid large quantities of dust.
- Avoid mechanical sway or vibration.
- The altitude of refrigerator's working position: lower than 2000m.
- Input voltage: within the range of 220-240V~.



●As the refrigerator is sensitive to the environmental temperature, it can not operate normally if it is installed in an environment other than the above. Please use it after improving the environment.

●It is prohibited to install the refrigerator in the open air environment. When the refrigerator gets wet in the rainwater, it may cause leakage of electricity or electric shock accident.

Installation site

For normal operation and optimum performance level of the refrigerator, its installation place shall conform to the following conditions:

- It can not be installed in a narrow, small and airtight space, the door frame of the room for placing it shall not be less than and lower than this product, and shall at least guarantee its normal passing in and out so as to avoid any maintenance difficulty and failure of in-time repair in occurrence of machine fault, causing spoilage to the stored articles.
- The ground at the installation place shall be solid and flat.
- It shall be well-ventilated without direct sunshine.
- Do not share a socket with other equipment, the plug and socket shall be well connected.
- Do not distort nor stress the power cord.
- If it is required to lengthen the power cord, the section area of the lengthened wire shall not be less than 2mm² and the length shall not be longer than 3m.
- Check the operating voltage before use, at the area where the voltage is not stable, use of a voltage regulator suitable for the motor load shall be considered for voltage stabilization. So that the normal input voltage is stabilized at 220-240V~, the power of the voltage regulator is greater than 1000W
- The refrigerator shall be guaranteed with reliable earthing.
- If the power socket has earth wire, check if the earthing is good before use.
- The interior is used for storing flammable and explosive reagents .
- The appliance is not suitable for use in explosion-hazard areas.



●Do not make refrigerator earthing via gas piping, water supply pipe, telephone line or lightning rod that may easily cause an electric shock.

●After installation, the power plug must be accessible to facilitate unplugging of the power cord in emergency. No articles shall block out the air vent of the refrigerator.

Preparation before use

1. Take off the packing material and the packaging tape

Take off all packing materials and packaging tapes for transportation.

Caution keep the plastic bag away from the children.

2. Check of accompanying accessories

Please check the box contents as per the packing list. If there is any mistake, please contact the aftersales department timely.

3. Storage condition

At least a 10cm gap shall be left around the storage box, to ensure the well air ventilation and to facilitate the heat radiation.

Caution Sufficient space shall be kept at the engine-room grilling, to facilitate maintenance and ventilation.

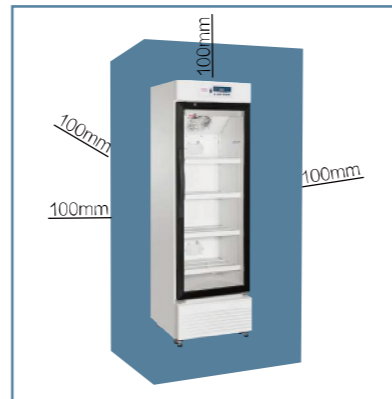

4. Adjustment of leveling leg

Please use a wrench to turn the horizontal leveling leg clockwise so that the horizontal leveling leg are extended outwards and supported on the ground. Make sure that the refrigerator is not movable in time of use.

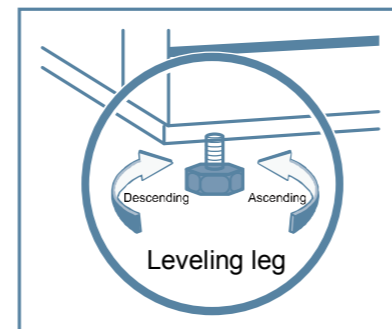

5. Standing

Do not power on the refrigerator firstly after leveling and cleaning. Let it stand still for over 24 hours before power it on so as to ensure normal running of the refrigerator..

6. Water collection tray

On the bottom, a stainless steel water collection tray is used to take down the water of evaporator. It is necessary to dump the tray regularly to prevent the water from spilling out to the tank.

It is recommended that users check the water level in the tray every five days, and pull out water.

Temperature indicator

The front control panel of the refrigerator is equipped with a temperature indicator that facilitates adjustment of the box temperature inside the refrigerator.

For first use, the refrigerator shall run at least for over 30 minutes before it reaches the stable state, do not make any adjustment before it is stabilized.

Schematic diagram of temperature indicator :

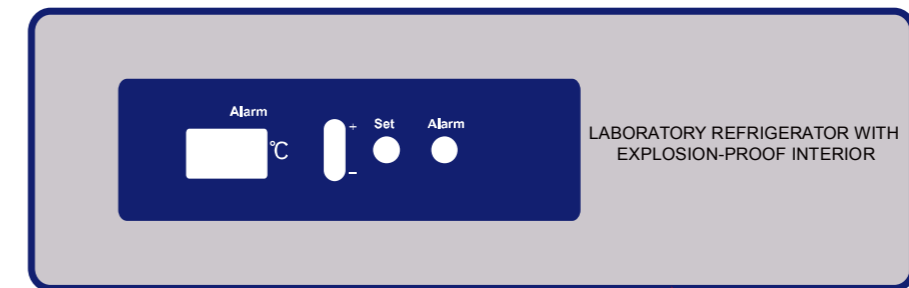

• Unlocking operation

When no operation is made by the user within 20s, the temperature setting, internal parameter setting and hi-low temperature alarm setting key are locked, the functions of the "Alarm" key to cancel the warning sound, the Max. and Min. temperature query, hi-low temperature alarm limit query are still effective, when it is required to unlock, press "+" key, the numerical value at inside temperature display area flickering 01, press "+" key or "-" key again to input the set password value, then press "Set" key to unlock, after successful unlocking, the buzzer beeps once, the box temperature display area normally indicates the temperature (if the password is wrong, the display area continues flickering of password value and will exit if no operation is made over 5s);

• Setting of password value

The Default unlocking password is "06", after unlocking, and press at the same time the "Set" and "Alarm" key for 5s, the display screen displays 06, then regulate the password value by pressing "+" and "-" keys, the password value can selected among 05, 06, 07..... 29,30. After setting the password value, press "Set" key to exit or automatically enter the lock-out state if no operation is made within 5s, the set password value is effective.

Moreover, in course of internal parameter setting and hi-low temperature alarm setting, it will automatically exit and indicate again the box temperature value if no operation is made within 10s.

• Temperature set

The preset box control temperature of the refrigerator before factory delivery is 5°C.

To set up the temperature inside the box, firstly conduct unlocking operation. Press again the "Set" key and quickly release, the display window displays the original setting value and flickering, when the setting value is flickering, adjust the setting value by pressing up key "+" or down key "-", the setting value changes 1 °C if it is pressed once, and it will

Control panel

HLR-118FL/118SF

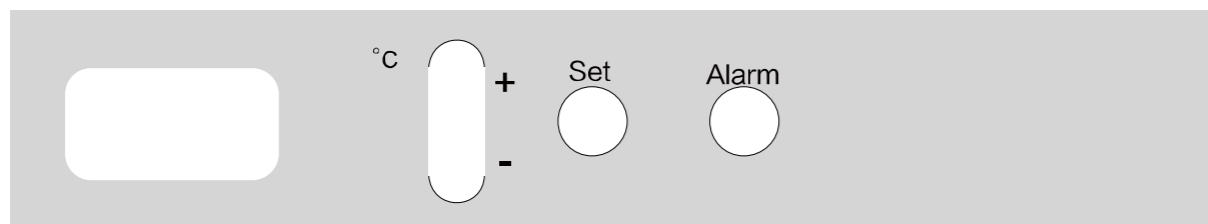

HLR-310FL/310SF

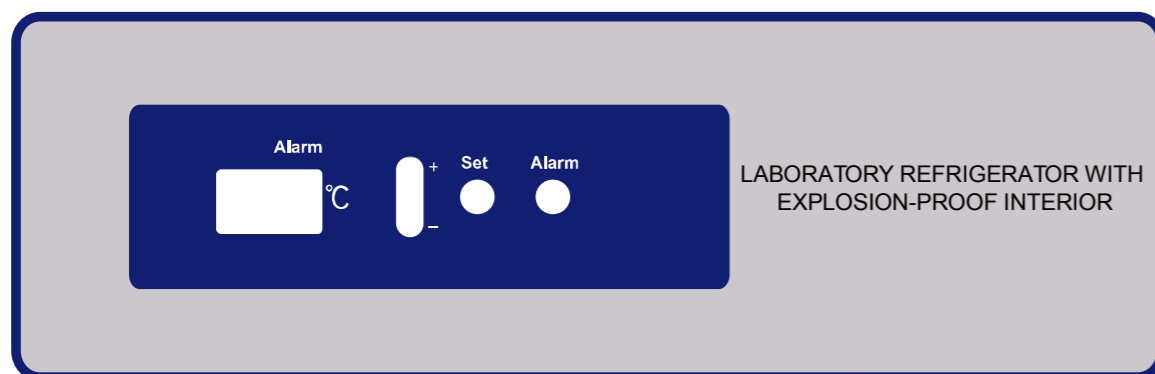

Initial Power-on

Please observe the following rules when conducting initial start-up and continuous running:

Connect the power cord to the dedicated socket of proper gauge when the refrigerator is empty, make sure the power supply is 220-240V/50Hz.

This refrigerator is preset at 5°C before factory delivery .

The sound alarm will ring after power-on and this is normal. At this moment, press the "Alarm" key on the control panel to cancel the alarm beep. The alarm indicator keeps flickering till the temperature sensor reaches the temperature range required.

The temperature can be stabilized at the set temperature after the refrigerator has been running for a period of time.

Start putting articles gradually into the refrigerator after completing a thorough inspection of the refrigerator.

- ! A person shall be specially assigned for daily check and record of the product operating conditions, in case the temperature inside the refrigerator is on the high side or on the low side, just transfer the articles to the other storage boxes till the fault is removed and then replace back the articles.
- ! The indicated temperature of this product may have a certain difference with the actual temperature inside the boxes due to refrigeration inertia, this is normal.
- ! Do not put any articles in the space between the bottom of the refrigerator's internal bladder and the bottom rack for fear of air duct clogging and affecting the temperature uniformity inside the boxes.
- ⊘ All the refrigerators are of storage equipment, and it is strictly forbidden to put excessive articles that are relatively too hot in one go, this will cause long time of running of the compressor without stop, slow drop of temperature, thus affecting service life of the compressor, the articles must be put in batches so that the temperature drops in steps till the required temperature is reached.
- ⊘ Do not spoil the refrigerating circuit.
- ⊘ Inside the refrigerator, do not use the electric appliance without production permission.

Operation of over-current protector

1. Mounting position: This device is mounted on the backside of the product, and there is a special warning sticker to mark it.
2. Working principle: In occurrence of any abnormalities found with the interior circuit of the product that exceed the protection limit of the over-current protector, this device will automatically spring up, cut off the connection with the external circuit and play the role of protecting the entire equipment circuit; at time of reuse, it is required to manually push down the device and the product is powered on for running.

Operation after power failure

The refrigerator has memory function to the setting values, after re-electrified following a power failure, the refrigerator will continue running as per the parameters set up before the last power failure.



Caution

- Once the power of the refrigerator is cut off, wait for over 5 minutes before it is reconnected so as not to damage the compressor or the system.
- Pull out the power plug when the refrigerator is not in service for a long time so as to prevent electric shock, leakage of electricity or fire due to aging of the power cord.
- If the refrigerator is left unused for a long time in an unattended area, make sure that children will not approach the refrigerator and the refrigerator door can not be closed completely.

Component Names

HLR-118FL/118SF



HLR-310FL/310SF

