

14500 Coy Drive, Grass Lake, Michigan 49240
734-475-2200 E-mail: sales@coylab.com
www.coylab.com

Hypoxic Cabinets
(In-Vivo / In-Vitro)
with O₂ Controller
Instruction Manual

Index

	<u>Page</u>
Warranty	2
Warnings	3
General Description	4
Setup Procedure (O2 Controller)	5
Setup Procedure (Gas Supply)	7
System Function	8
Operation and Calibration	9

WARRANTY

This product is warranted against defects in material and workmanship during the first 12 months after original date of shipment.

The factory will, at its option, repair or replace defective material within this period at no charge for parts and labor.

All returns or exchanges must first be authorized by COY LABORATORY PRODUCTS, INC.

PHONE: 734-475-2200

FAX: 734-475-1846

COY LABORATORY PRODUCTS, INC.

14500 COY DRIVE

GRASS LAKE, MI 49240

The responsibility of COY LABORATORY PRODUCTS, INC. is limited to the purchase price of this product, and COY LABORATORY PRODUCTS, INC. will not be responsible for any consequential damages.

This warranty does not cover damage in shipment or damage as a result of improper use or maintenance of this product. This warranty does not cover damages caused by excessive line transients on the AC supply line.

WARNINGS

- 1. The calibration of the sensor must be checked frequently as erroneous low readings can result from a degraded sensor.**
 - 2. Gas pressures into the back of the Oxygen Controller must not exceed 10 PSI.**
 - 3. The output of the O₂ Controller must be regulated using the controls on the front of the Controller. If the gas flow is set too high, there is a danger the Sensor will not detect the rapid change, thus causing the gas level to exceed your set point value.**
 - 4. Never obstruct gas flow in or out of the Chamber Relief Valves.**
 - 5. Never attempt to service the O₂ Controller. Call COY LABORATORY PRODUCTS, INC. for assistance.**
 - 6. Never put an open flame or create a spark in a Chamber, especially under hyperoxic conditions.**
 - 7. The sensor cell membrane is delicate. Do not scratch, puncture, or permit sharp objects to touch the cell face. Sensor failure due to mishandling voids the sensor warranty.**
 - 8. If the sensor becomes wet you will need to take it out of the chamber and let it dry out in room atmosphere for at least 24 hours before use. Too much moisture can cause sensor errors and not enough could lead to cells drying out. A small amount of water (~ the top of a 100 mm petri dish) may be added to the cabinet to ensure cells do not dry out.**
- *** Water should not condense on the walls of the cabinet.**
- 9. Do Not Hold O₂ sensor straight up. It needs to be in the horizontal position or facing straight down.**
 - 10. The sensor will need to be recalibrated every month or so after 6month to a year of its life.**

General Description

The Oxygen Controller utilizes a unique galvanic sensor to measure up to 100% concentration in atmospheric environment. The sensor is supplied with a 5 foot cord, is temperature compensated, and is totally sealed from the environment. The sensor must not be exposed to pressures exceeding 10si (pounds per square inch). There is no membrane replacement or maintenance of the sensor during its expected life of 2 or more years.

All control functions are programmable from the front panel. Self diagnosis with indication of faults is standard. The non-volatile memory retains all process parameters when power is off.

The sensor is always operating and does not require a warm up period. To prolong its life, DO NOT STORE IN A WARM OR HOT AREA. Even when disconnected and in storage, the sensor is working because of its internal temperature compensating network. Storage in a refrigerator will slow the kinetic energy of the cell and prolong its life.

O₂ Controller Setup Procedure

1. Remove Controller from the package.
2. Remove the sensor from the bag.
3. Locate the O₂ sensor port on the Chamber/Glove Box/Cabinets.
(*certain custom built units may have different locations for the port based on configurations*)
 - On COY Aluminum Glove Boxes port is located on the center of the back panel.
 - On Coy Polymer Glove Boxes the port is located on the top right side of the glove box.
 - On COY Flexible Vinyl Chamber port is located behind the airlock.
 - On Coy In-Vivo / In-Vitro Cabinets port is located on the top of the cabinet.

Mounting O₂ sensor through Feed Thru-Port

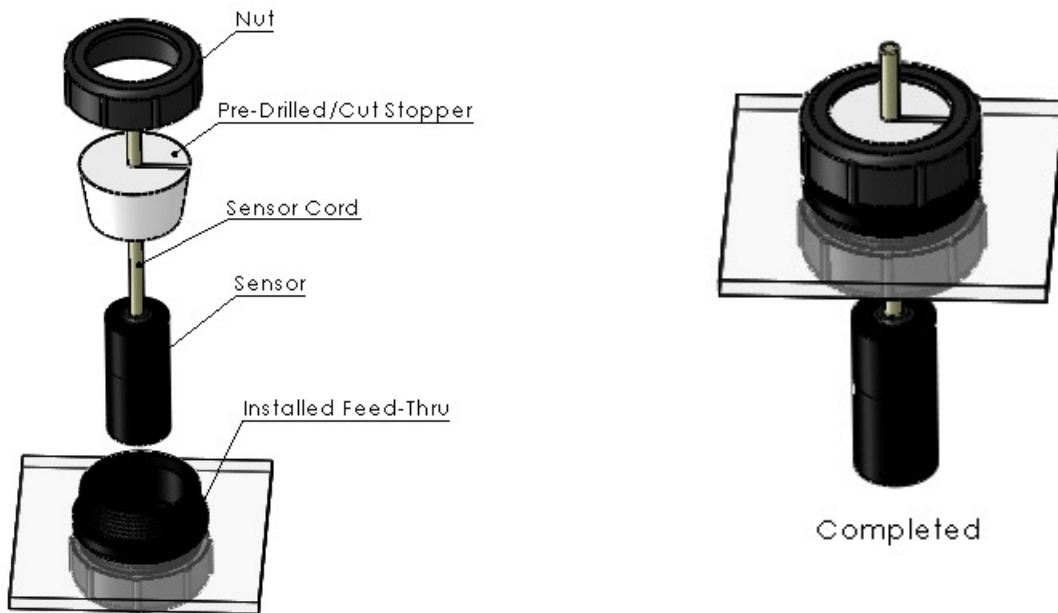

4. Mounting O₂ sensor into chamber:

- Step 1)** Position the Chamber as desired, and then place the Oxygen Controller on the Exterior Shelf Provided (Shelf located on Top of Polymer unit or Side of an Aluminum unit).
- Step 2)** Plug the Oxygen Sensor into the jack on the back of the Controller.
- Step 3)** Feed entire sensor down through the mounting Feed thru port as seen above.
- Step 4)** Using the predrilled, precut rubber stopper insert the O₂ sensor cord. Push the rubber stopper down into the port as far as possible and screw the nut down tightly.

Note: Make sure the sensor hangs about 3-4 inches into the chamber.
Rotate sensor so that serial number is visible.

Figure #2 Rear Panel of Oxygen Controller

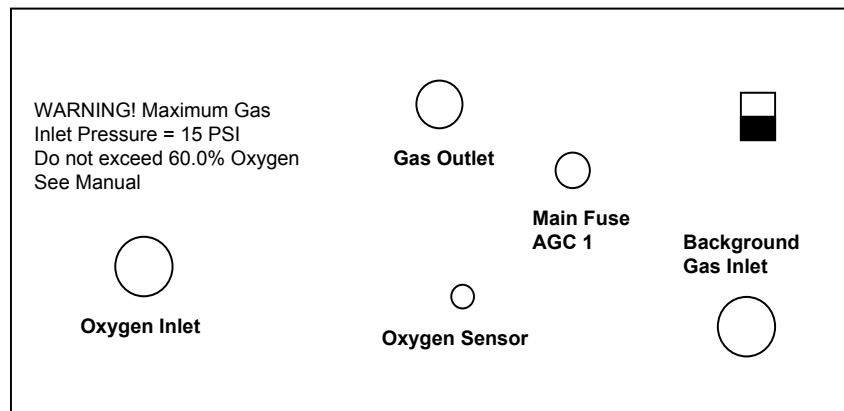

5. Measure and cut a length of tubing to reach from the controller gas outlet to the cabinet inlet. Place a female fitting on each end of tubing. Place 2 ty-wraps around the hose barb on the female fittings and pull them as tight as possible. Cut off excise ty-wrap.

WHEN CUTTING TUBING, THE ENDS SHOULD BE AS SQUARE AS POSSIBLE

Figure # 3 Tubing connection to Quick Disconnect Fitting

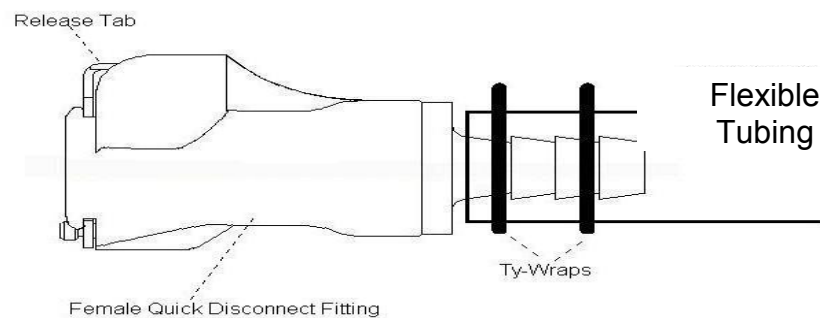

6. Attach this tubing from the Controller Outlet to the Cabinet. When fitting is seated correctly, you will hear a “click”.
7. Take an end of each tubing and place a female fitting onto that end. Place 2 ty-wraps around the hose barb and pull them tight as possible. Cut off excise ty-wrap.
8. Attach one tubing to the hose barb on the O2 regulator. (**if O2 will not be used then do not connect an O2 line**) Place 2 ty-wraps around the hose barb and pull them as tight as possible. Cut off excise ty-wrap. Attach the other end to the “Oxygen Inlet” on the back of the Controller. When fitting is seated correctly, you will hear a “click”.

9. Attach the other tubing to the hose barb on the background gas regulator. Place 2 ty-wraps around the hose barb and pull them tight as possible. Cut off excise ty-wrap. Attach the other end to the “Background Inlet” on the back of the Controller. When fitting is seated correctly, you will hear a “Click”.
10. The Oxygen Controller is now ready to use. Be sure the safety relief valves on the cabinet work properly before leaving the equipment to operate unattended.
11. The cabinet is designed to fit into an incubator. Once the desired set point is established disconnect the gas supply lines and sensor from the hypoxic cabinet. Then place entire cabinet into incubator. (If long incubation periods are required then two pass thrus will be needed in the incubator, one for the sensor and one for the gas line.)
12. Make sure the cabinet is level by using the leveling feet provided.

Set up for Hypoxic Cell Culture

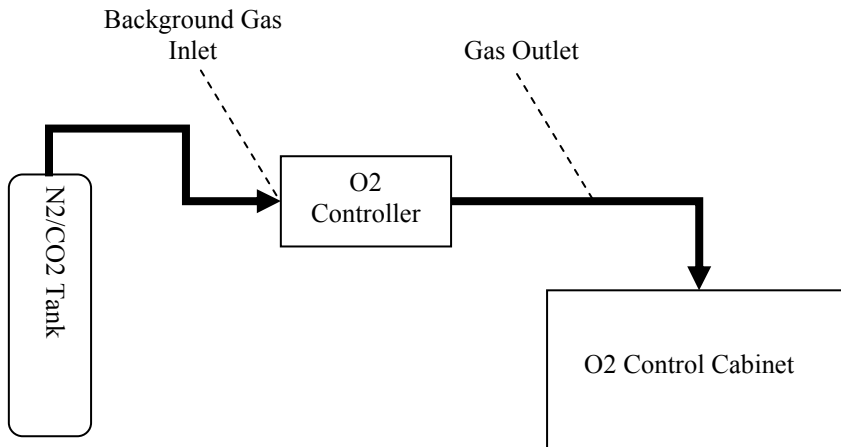

Set up for Hypoxic Cell Culture with Optional CO2 Controller

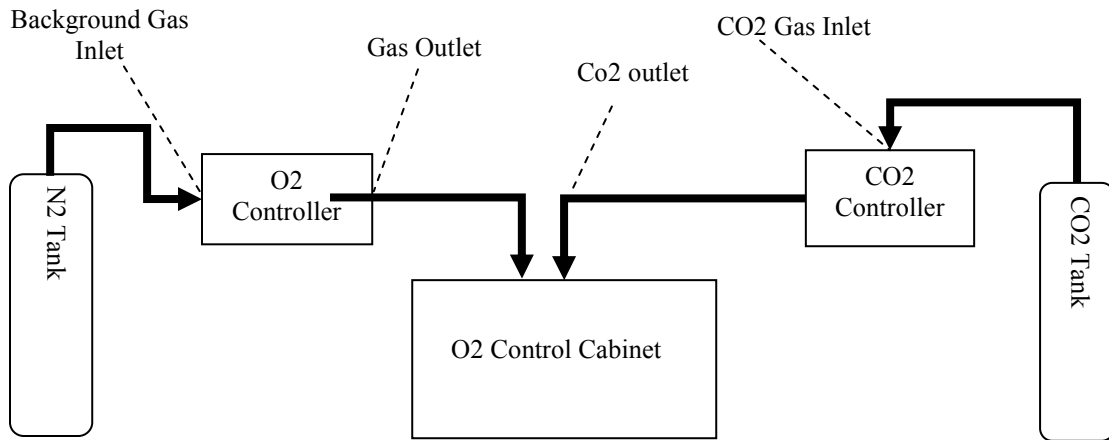

Set up for Hypoxic InVivo Studies

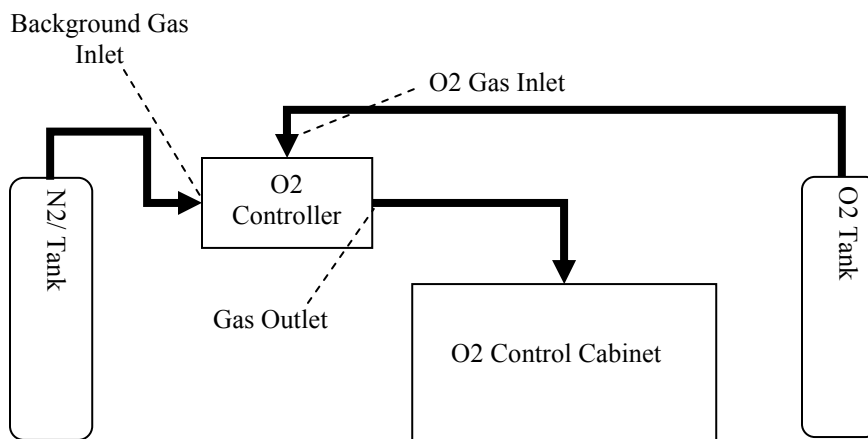

Gas Supply Setup

Passive CO2 Control

If optional CO2 Control System has been purchased skip this part

To maintain the 5% CO₂ level required for certain buffers to function properly, use the following table to spike each one of the gases going into the Oxygen Controller with the appropriate level of CO₂ based on desired O₂ levels.

Desired Concentration of Oxygen	Air Displace to %	%CO ₂ Mix required	Desired % Co ₂	%CO ₂ Concentration in N ₂
20.80	100.00	0.00	5.00	N/A
15.00	72.12	27.88	5.00	17.9310
10.00	48.08	51.92	5.00	9.6296
5.00	24.04	75.96	5.00	6.5823
2.00	9.62	90.38	5.00	5.5319
1.00	4.81	95.19	5.00	5.2525
0.50	2.40	97.60	5.00	5.1232
0.10	0.48	99.52	5.00	5.0242

System Function

The Oxygen Controller is intended to maintain an oxygen level in a chamber/glove box by sensing the current concentration, and then opening the appropriate solenoid valve to allow gas to flow and purge the system. The Oxygen set point value (SV) is used to set the oxygen in the chamber/glove box.

Under normal use, only one gas line will be open at a time. The flow must be adjusted using the Flow Meters on the front of the Controller (see Table below). **The gas flow on the Flow Meters can only be adjusted when gas is flowing through that particular Valve.** To adjust the Flow Meters, simply turn the black Knob on the front of the Flow Meter. Clockwise increases flow, counter clockwise decreases flow. If the Process Value (PV) overshoots the Set Point (SP) then the flow rate is set too high and must be adjusted down.

UNDER NO CIRCUMSTANCE SHOULD THE INLET PRESSURE EXCEED 15 PSI. GAS PRESSURES IN EXCESS OF 10 PSI MAY DAMAGE THE O₂ CONTROLLER AND VOID THE WARRANTY.

To obtain uniform O2 concentration throughout the chamber, the small circulating fan must be on at ALL times. Please note the addition of a COY Fan Box (heated or unheated) eliminates the need for this fan.

The alarm (AL) and temperature (C°/F°) functions are not included with O2 Controller; therefore, these indicator lights will not work.

During operation, the Chamber will pressurize so that the sleeves may begin to stand out. This excess pressure will be removed by the COY Automatic pressure relief valves installed on the COY Glove Boxes. Be sure that these pressure relief valves are not blocked.

Below are recommended Flow Rates

Type/Size	Flow Rate (SCFH)	Flow Rate (SCFH)
	O ₂ Gas*	Background Gas
<i>In-Vitro Cabinets</i>		
Model 1	< 0.2	≤ 1
Model 2	< 0.2	≤ 1.5
Model 3	≤ 0.2	≤ 2.5
Model 4	≤ 0.4	≤ 4
<i>In-Vivo Cabinets</i>		
Model 15	≤ 1	≤ 6
Model 30	≤ 2	≤ 10
Model 60	≤ 4	≤ 20

*NOTE: The O2 Flow Rates assume a 100% tank of O2 is used. For forced air or other % of O2 rates will have to increase. An Oxygen tank may not be necessary for operating in Hypoxic conditions.

Operation/set point of O₂ Controller

1. Plug the Controller into an electrical outlet.
2. Turn the unit on using the rocker switch on the back.
3. After going through a self test routine, the display will show a red and green number. The red number indicates Present Value (PV) and the measured O₂ concentration and the green number is the Oxygen Set Point Value (SV).
4. Use Figure # 4 to adjust the set point. Press the ▲▼ keys to adjust the SV (green numbers displayed) to desired O₂ setting.

Figure # 4 - O₂ Controller Display



- Top Red Number – PV (present value)
- Bottom Green Number – SV (set-point value)
- Red Number on Side – Indicate gas output ON
1 = O₂ Gas / 2 = Background Gas
- ▲ ▼ Keys – Adjust SV up or down
- ⌂ Key – Not Used
- ∞ Key – Not Used
- EZ Key – Not Used
- Yellow Zone Indicator – Not Used

5. Once SV display is adjusted to desired O₂ setting the controller is ready to start controlling O₂ in the Chamber/Glove Box/Cabinet.

Calibration of the O₂ Controller

If the High accuracy kit was purchased please follow Calibration instructions for High Accuracy manual. If you cannot find the High Accuracy calibrations manual please contact Coy. techservice@coylab.com

Do Not Place O₂ sensor straight up. It needs to be in the horizontal position or facing straight down.

The sensor has an expected life of greater than 2 years. During that time, there may be a downward drift in the O₂ measurements. It is best to periodically check the calibration.

To do this:

1. Remove the sensor from the Chamber.
2. Plug the opening with the sensor fitting to maintain chamber integrity.
3. **Allow the sensor to equilibrate to ambient conditions for at least 30 minutes.**
4. The ambient oxygen concentration should read 20.9% +/- 1%.
5. If it does not, adjust the percent potentiometer (labeled %) on the front of the O₂ Controller until 20.9% +/-1% is read.

To test for zero:

1. Place the sensor in a 100% nitrogen atmosphere.
2. Allow it to equilibrate for 30 minutes.
3. The Controller display should read 0%.
4. If it does not, adjust the zero potentiometer (labeled Zero) on the front panel to 0%.

Contact Coy Laboratory Products, Inc. if the sensor requires frequent recalibration at 734-475-2200 or email techservice@coylab.com.

Do Not Place O₂ sensor straight up. It needs to be in the horizontal position or facing straight down.

(If you have purchased High Accuracy Kit refer to that manual to calibrate unit)

The sensor has an expected life of greater than 2 years. During that time, there may be a downward drift in the O₂ measurements. It is best to periodically (once a month) check the calibration. To do this, remove the sensor from the Chamber, plug the opening with the sensor fitting to maintain chamber integrity and **allow the sensor to equilibrate to ambient conditions for at least 1 hour.** The ambient oxygen concentration should read 20.9% +/- 1%. If it does not, adjust the percent potentiometer (labeled %) on the front until 20.9% +/-1% is read.

To test for zero, place the sensor in a 100% nitrogen atmosphere and allow it to equilibrate for 30 minutes. The Controller display should read 0%. If it does not, adjust the zero potentiometer (labeled Zero) on the front panel to 0%.

Contact Coy Laboratory Products, Inc. if the sensor requires frequent recalibration at 734-475-2200 or email www.techservice@coylab.com .

Replacement parts and related accessories:

8522110	High Accuracy O2 Calibration Kit
2200070	Sensor, Oxygen Control